

CRITICAL POTENTIALS IN SECONDARY ELECTRON
EMISSION FROM IRON, NICKEL, AND
MOLYBDENUM

BY ROBERT L. PETRY

ABSTRACT

Secondary electron emission from iron, nickel and molybdenum targets for primary voltages 0 to 1500.—The tube used was designed so as to minimize disturbing factors, all metal parts were glowd before assembly, and the tube was baked before each set of runs. In addition the targets were thoroughly cleaned by heating to bright red by electronic bombardment from an auxiliary filament until a permanent condition was obtained as indicated by the curves. The pressure was kept below 10^{-6} mm. Both the secondary emission I_1 and the primary current I_2 were measured by a null method of high precision (to 0.1 percent or less). The ratio I_1/I_2 was found (1) to vary only 2 percent as the retarding potential between the plate and surrounding box was increased from 3 to 10 volts, so 6 volts was considered sufficient; (2) to vary only slightly with the primary current; (3) to be unchanged when the earth's magnetic field was neutralized. The final curves, for all three metals after heat treatment, are nearly alike, the value of I_1/I_2 rising to a maximum of about 1.30 at about 348 volts for iron, 455 volts for nickel and 356 volts for molybdenum. From slight breaks (changes of slope) in the curves, some 25 critical potentials were located for iron, 16 for nickel and 20 for molybdenum. The values below 40 volts for iron (7.3, 11.6, 14.4, 18.3, 22.6, 25.0 and 29.0) and for nickel (6.2, 9.3, 9.9, 11.8, 15.1, 22.6, 24.4, 31.4, 35.0) agree fairly well with critical potentials for soft x-rays determined by Thomas. This suggests that there is a common phenomenon involved in the production of secondary emission and of soft x-rays which is evident at the lower voltages but which is masked at higher voltages by other processes not yet understood.

INTRODUCTION

IT HAS been known for some time that when electrons strike a metal surface in a vacuum they cause the emission of secondary electrons from the metal. The work of the earlier investigators¹⁻¹⁰ in this field

¹ A. Gehrts, *Ann. der Phys.* **36**, 995 (1911).

² N. Campbell, *Phil. Mag.* **22**, 276 (1911); **25**, 803 (1913); **28**, 286 (1914); and **29**, 369 (1915).

³ A. W. Hull, *Phys. Rev.* **7**, 1 and 141 (1916).

⁴ H. M. Dadourian, *Phys. Rev.* **14**, 434 (1919).

⁵ J. T. Tate, *Phys. Rev.* **17**, 394 (1921).

⁶ Davisson and Kunsman, *Science* **54**, 394 (1921).

⁷ I. G. Barber, *Phys. Rev.* **17**, 332 and 292 (1921).

⁸ L. E. McAllister, *Phys. Rev.* **21**, 122 (1923).

⁹ Horton and Davies, *Proc. Roy. Soc.* **97A**, 23 (1920); *Phil. Mag.* **46**, 129 (1923).

¹⁰ E. W. B. Gill, *Phil. Mag.* **45**, 864 (1923).

has shown that (1) the number of secondary electrons emitted depends on the nature of the metal and is a function of the velocity with which the primary electrons strike, (2) the number of secondary electrons, at the higher voltages, may exceed the number of primary electrons striking, so that reflection alone is not sufficient to account for the phenomenon, and (3) the emission is dependent upon the previous heat treatment of the metal bombarded. Recently Farnsworth¹¹ has made a careful study of the ratio of secondary emission to primary current for various metals after careful heat treatment and has investigated the effect of heat treatment of copper upon its emission. Stuhlman¹² observed, in the case of iron, that the relation between the number of secondary electrons per primary electron and the velocity of the primary electrons changes more or less abruptly at certain values of velocity, thus indicating critical velocities (or voltages) for secondary emission.

The object of the present investigation has been to determine more exactly whether the number of secondary electrons emitted per primary electron changes gradually as the velocity of the primaries is increased, or whether at certain critical velocities this number changes abruptly. It was assumed that a considerable part of the secondary emission, if not all of it, might be due to the photo-electric action of soft x-radiation which is caused by the electronic bombardment of the metal surface and which acts photo-electrically on the metal itself in which it originates; if this is the case, a relation or correspondence should be found between these critical velocities for secondary emission and those for x-ray emission.

APPARATUS AND PROCEDURE

The apparatus used was of the same form as that used by Campbell² and A. W. Hull.³ Electrons from a filament F_1 (Fig. 1) were drawn toward a series of diaphragms with openings SSS by a field V_1 , and all those passing through the openings struck a metal plate P . Any electrons reflected from P or emitted as secondary electrons were drawn by a field V_2 to a nickel cylinder CC almost completely surrounding P . The current to CC was measured by a galvanometer G_1 , and the total current through SSS by a second galvanometer G_2 .

The plate P was mounted through a ground glass joint sealed on the outside with DeKhotinsky cement, so that it could be replaced or

¹¹ H. E. Farnsworth, Phys. Rev. **20**, 358 (1922) and **25**, 41 (1925); Proc. Nat. Acad. Sci. **8**, 251 (1922).

¹² Stuhlman, Science, **56**, 344 (1922); Phys. Rev. **25**, 234 (1925).

taken out for polishing without cutting the tube. The ground glass joint was long and was kept free from cement except at the outside, where it was kept cool by water circulation; consequently the cement vapor pressure was small because of the difficulty of diffusion between the ground glass surfaces and because of rapid evacuation by the pumping system. The filament F_1 was mounted similarly through another ground glass joint.

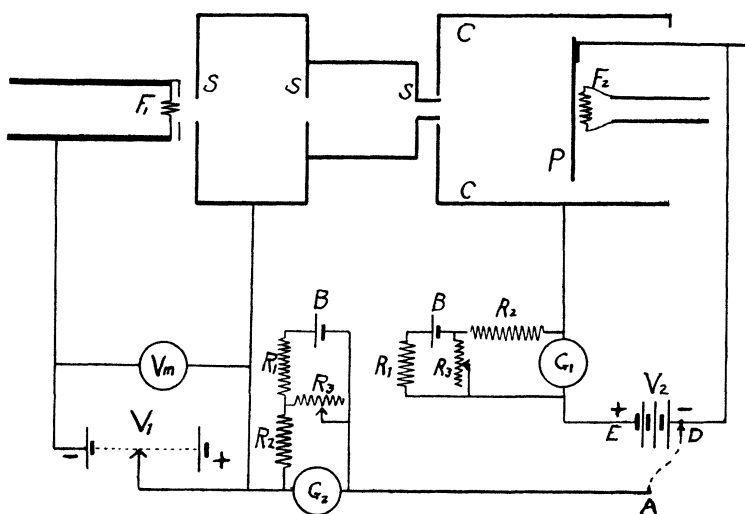

Fig. 1. Diagram of apparatus and electrical connections.

The filament F_1 was of 10 mil (.25 mm) tungsten wire helically wound in three closely-spaced turns of small diameter so as to give a small, nearly equipotential source of electrons. The heating current required varied from 5.8 to 6.3 amp., with a potential drop of 1.1 to 1.2 volts. This current was supplied by a large capacity insulated storage battery, which was used under conditions suitable for giving the greatest possible constancy of the current. A rheostat consisting of a nichrome ribbon immersed in kerosene, with heavy clamp contacts, was found to furnish a very steady control resistance. A focusing ring of nickel sheet was mounted a short distance in front of the filament but the potential applied to it was found to have little effect upon the amount of current passing through the openings, and in most of the runs it was left connected to the negative filament terminal.

The system of three diaphragms SSS and the cylinder CC were of nickel and both were mounted directly against the walls of the glass tube which was of 3.5 cm diameter. These two parts were so designed

as to give about an inch of glass insulation between them. The diaphragms were spaced 1.5 cm apart and the openings were circular holds 2.5 mm in diameter. The distance from the filament F_1 to the plate P was 5 cm.

All metal parts were glowed out in an induction furnace before being assembled, in order to remove occluded gases. Before each set of runs all parts of the tube, with the exception of the water cooled DeKhotinsky seals and two charcoal traps in series with it, were baked out for several hours in electric furnaces at a temperature of about 400°C. Liquid air was kept on a third trap continuously in order to keep mercury and oil vapors from entering the tube. A second filament F_2 was mounted directly back of the plate P , and after the tube was allowed to cool the plate was glowed out several times at a bright red heat by electronic bombardment from F_2 in order to remove occluded gases from the surface to be bombarded. The temperature used in this process was sufficient to cause the iron target to show signs of melting at the point nearest the filament. As a result of these precautions, with the diffusion pump running continuously and liquid air on both charcoal traps, during runs the pressure was too small to be detected by a McLeod gauge reading to $(10)^{-6}$ mm of mercury.

The accelerating potential V_1 was varied from 0 to 1500 volts. Storage cells were used up to 300 volts, while for higher ranges a motor-generator set run by storage batteries was used. V_1 was adjusted by a 12,000 ohm potentiometer system and was measured by a Weston Laboratory Standard Voltmeter with a scale of 750 divisions and with suitable multiplying resistances to give convenient ranges.

The retarding potential V_2 was usually about 6 volts and was furnished by dry cells. Part of the runs were taken with the connections shown but most of the later ones were taken with A (Fig. 1) connected to E instead of to D , so that the strong field in the close gap between the projecting tube of SSS and the edge of the hole in the end of CC was avoided. The accelerating field from F_1 to P was then $V_1 - V_2$. The results from the two methods of connecting were indistinguishable.

It will be noted that the current reflected directly back through the opening in the end of CC was lost. This could cause the observed ratio of secondary electrons to primary electrons to be smaller than the actual ratio. However, the solid angle subtended at P by the opening was not more than 2.5 percent of the entire solid angle and the loss was assumed to be negligible. In any case this source of error should not affect the location of critical potentials.

Multiple reflection and emission from CC back to P have also been neglected. However, velocity distribution measurements by Farnsworth and the writer indicate that a collecting potential V_2 of 6 volts should be sufficient to avoid any considerable final reflection or emission from CC to P since a large proportion of the secondary electrons have velocities insufficient to carry them against this collecting field.

The current to CC was usually of the order of $(10)^{-6}$ amp. and was measured by a galvanometer G_1 of sensitivity better than $(10)^{-9}$ amp. per scale division. In order to measure the total current coming through SSS and striking P the second galvanometer G_2 was connected so as to measure the current to both P and CC ; that is, the electrons remaining on P plus those reflected or emitted from it to CC . The filament current was adjusted so that, except at the lowest voltages, this current through G_2 was greater than $(10)^{-6}$ amp., while the sensitivity of G_2 was about $5 (10)^{-9}$ amp. per scale division.

In order to obtain greater precision the galvanometers were not shunted in measuring the larger currents, but were used at full sensitivity for all ranges by a method of balancing currents, in which the galvanometer measured only the residual current after approximate balancing by the following potentiometer method. Whenever the scale reading of one of the galvanometers became large it was reduced to near zero by sending an additional current through the galvanometer in the reverse direction by means of a storage cell B connected through two high resistances R_1 and R_2 and a shunt R_3 of low variable resistance. In this way the major part of the current to be measured was balanced by an accurately known reverse current, while the galvanometer, at full sensitivity, measured the difference between these two. As the currents increased, during a run, it was necessary to change this balancing current at intervals; the correction factor to be added at each step-down of this kind in the scale reading was not computed but was observed directly for each change of R_3 by noting the difference between readings taken before and after changing R_3 , all other factors remaining constant. A reliable check on the steadiness of conditions during this change for one galvanometer was given by observations on the readings of the other galvanometer. Below 50 volts the currents were generally satisfactorily steady but above that range there were generally slow and regular drifts of both currents in the same ratio; under these conditions duplicate readings were taken on changing R_3 in order to determine the correction satisfactorily. The largest current

measured in this way was the equivalent of about 4000 scale divisions of the galvanometer used.

The ratio of the current through G_1 to the current through G_2 gives the number of secondary electrons emitted from the target per electron striking it. This ratio I_1/I_2 was plotted as ordinate against V_1 (or $V_1 - V_2$ with changed connections) in volts as abscissa. The resulting curves showed breaks or places of rapid change of slope. In order to locate these accurately, readings were taken at small voltage intervals. In the region 0 to 24 volts the intervals were 0.2 volts; in the region 650 to 1500 volts, 10-volt intervals were used, while intermediate intervals were used in the intermediate regions. The correction in the value of V_1 for initial velocity of the electrons was estimated at 0.2 volts and for potential drop to the middle of the filament was 0.55 volts; but the correction for contact difference of potential is not known accurately. Hence, the total correction due to these causes was checked experimentally for iron and nickel by observing the retarding potential $-V_2$ with A connected to E , which was necessary to keep the majority of electrons from reaching P under an accelerating field V_1 . This correction was -0.4 volts for iron and $+0.8$ volts for nickel.

The present investigation differs from other studies made in the same field in the smaller voltage intervals used in taking readings and in the precautions taken to measure the currents and the accelerating voltage precisely while avoiding disturbing factors.

RESULTS

Preliminary observations were made to determine the effect upon the ratio of secondary emission to primary current of four factors, viz., variation of collecting potential V_2 , variation of filament current, compensation of the earth's magnetic field, and heat treatment of the target.

An increase of V_2 from 3 to 10 volts increased the ratio I_1/I_2 by about 2 percent in most cases. Increasing V_2 from 6 to 20 volts had a smaller effect. In general so long as V_2 was not negative it had little effect upon the ratio I_1/I_2 and none at all upon the position of breaks in the graph of I_1/I_2 plotted against V_1 .

Results taken with different filament currents were as consistent as regards critical potentials as were runs taken with the same filament current, hence various filament currents were used throughout and the results were plotted without regard to this factor. In general, however, with an increase of filament current the ratio I_1/I_2 showed a tendency

to decrease slightly; this shows that not the absolute values of the ratio but its relative values for any one run were determined precisely.

A few runs were taken with two long bar magnets placed so as to compensate the earth's magnetic field approximately over the path of the primary electrons. No difference could be distinguished between the results of these runs and the results of runs taken without the magnets. The nickel parts of the apparatus may have provided considerable magnetic shielding for the electron paths.

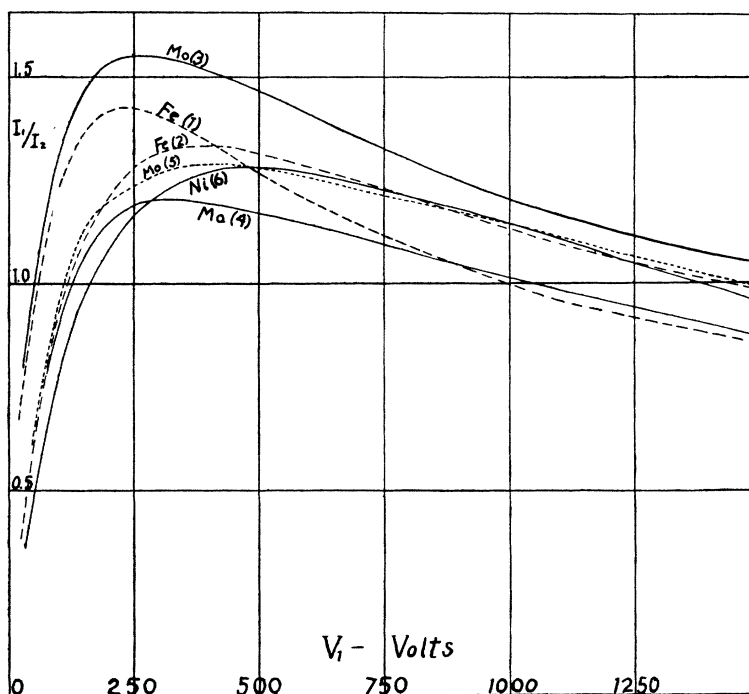

Fig. 2. Number of secondary electrons emitted per primary electron, 0-1500 volts.
 Curves 1 and 2, Fe before and after heat treatment.
 Curves 3 and 4, Mo before and after partial heat treatment.
 Curve 5, Mo in final state.
 Curve 6, Ni after heat treatment.

The effect of previous heat treatment of the target was not investigated at length. In general this reduced the ratio I_1/I_2 and the curves approached a limiting form in agreement with results found by Farnsworth. A maximum in the ratio was found at about 225 volts for iron and at about 275 volts for molybdenum before glowing out the target by electronic bombardment (curves 1 and 3, Fig. 2); similar maxima

in the same general region, 200 to 275 volts, were reported by Gehrts¹ for copper, aluminium and cobalt targets not glowed out in vacuo. But it was found that after thorough heat treatment this maximum came permanently at 356 volts for molybdenum and at 348 volts for iron (curves 2 and 3, Fig. 4).

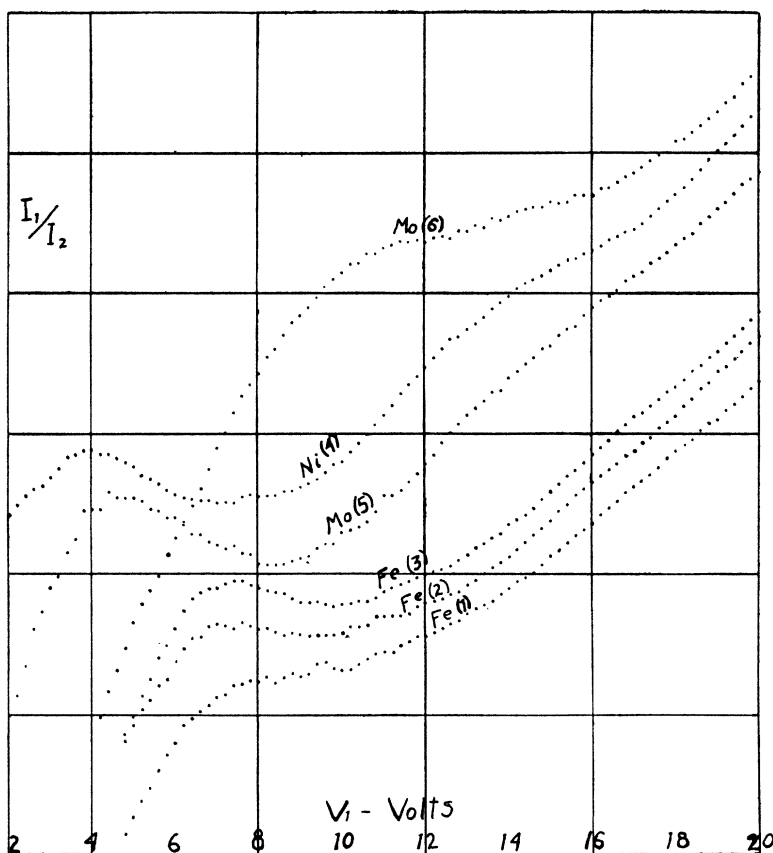

Fig. 3. Secondary emission curves, 2-20 volts. Different scales of I_1/I_2 are used.
 Curves 1, 2, and 3, Fe, after thorough heat treatment.
 Curve 4, Ni after thorough heat treatment.
 Curves 5 and 6, Mo after thorough and after only partial heat treatment.

Heating to a dull red heat failed to bring the molybdenum target to a final state; curves taken at this stage are different in form at low voltages from those taken after the target had been glowed out at a bright red heat (curves 5 and 6, Fig. 3). Also a maximum value of the ratio was reached at 315 volts in this stage instead of at the final value

of 356 volts (curves 1 and 2, Fig. 4). After the target was heated to a bright red heat a few times further heating produced no changes in the shape of the curves.

Breaks are found in the curves for both iron and molybdenum taken before the final state was reached. (No curves of this kind were taken for nickel.) These breaks, however, are not found at the same voltages

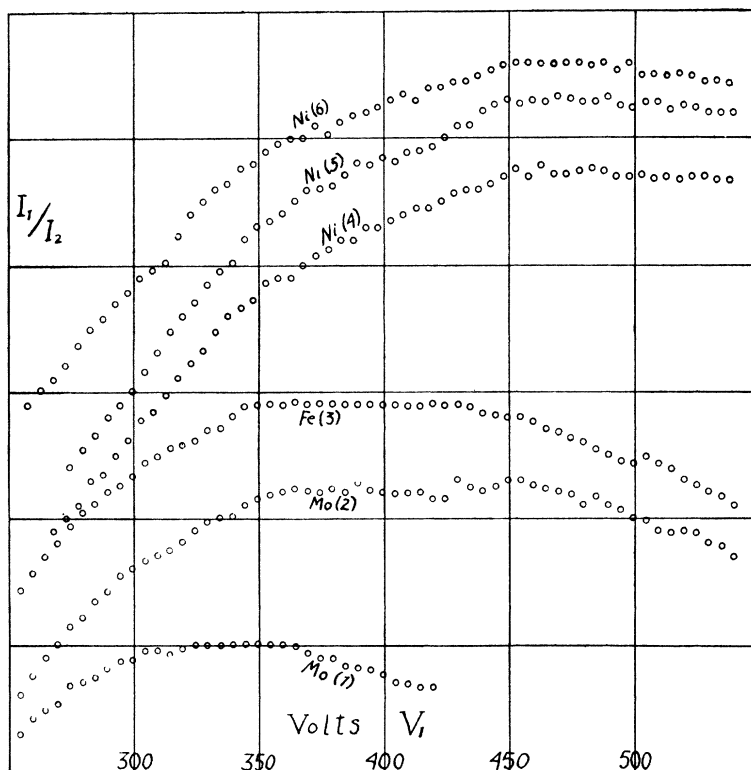

Fig. 4. Curves in region of maxima, 250-550 volts. Different scales of I_1/I_2 are used.
 Curves 1 and 2, Mo after partial and thorough heat treatment.
 Curve 3, Fe after thorough heat treatment.
 Curves 4, 5 and 6, Ni after thorough heat treatment.

as are those for the heat-treated targets and are in general less definite, with more gradual curvature. Even after the final state was reached the ratio at any given voltage might vary a few percent from one set of runs to the next, but the position of breaks was not affected by the change of ratio.

Curves 1 and 2, Fig. 2, show the general variation of I_1/I_2 with velocity of impact up to 1500 volts, for iron before and after glowing

out the target. Curves 3, 4 and 5 show results for molybdenum untreated, after being heated to dull red heat, and in its final state; curve 6 is for nickel thoroughly heat-treated.

Fig. 3 shows the region 2 to 20 volts. Curves 1, 2 and 3 show results for iron taken at different times, all after heat treatment. In the region 7 to 10 volts the slope of the curve was sometimes positive and sometimes negative, but was always set off from the regions adjoining it by

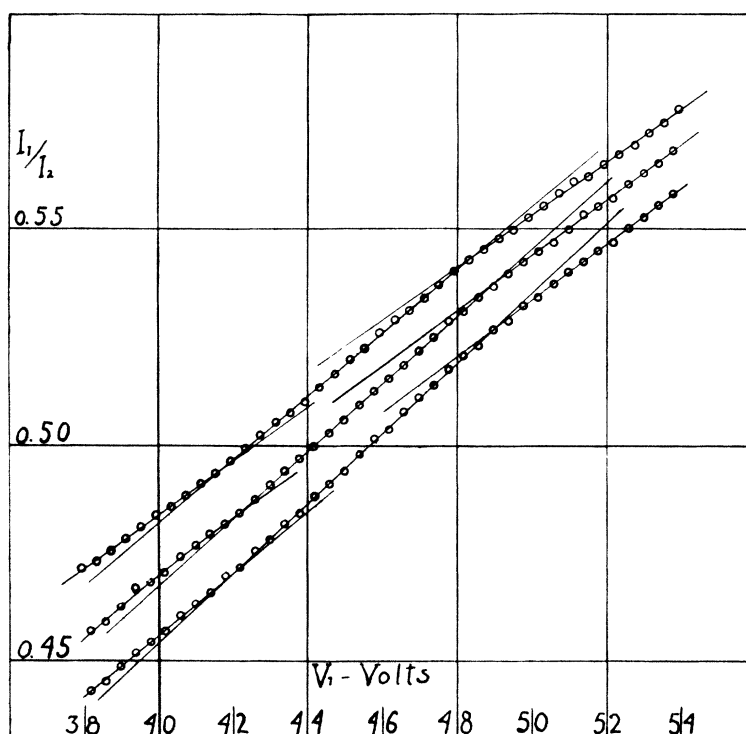

Fig. 5. Secondary emission curves for Fe, 36-56 volts.

changes of slope. Curve 4 is for nickel and curve 5 for molybdenum after careful heating. Curve 6 shows the results for molybdenum after heating to a dull red heat; there seems to be no connection with curve 5. In order to avoid confusion in plotting, these curves are not all plotted to the same scale of I_1/I_2 .

Fig. 4 shows the region of the maximum, with I_1/I_2 plotted on different scales for different curves. Curve 1 is for molybdenum after partial treatment; the maximum value of I_1/I_2 is 1.205 secondary electrons per primary electron. The other curves are all for targets in

the final state and are as follows: curve 2, molybdenum, with maximum value of I_1/I_2 equal to 1.284; curve 3, iron, maximum value of 1.323; curves 4, 5 and 6, nickel, with maximum values of 1.282, 1.280 and 1.253 respectively.

TABLE I
Critical primary potentials for iron

Critical potential (volts)	Weight factor	Sign	General breaks	Soft x-ray levels (Thomas)	Critical potential (Stuhlman)
.....				3.3
7.3	10	+	+7.3	7.3	8.5
11.6	10	-	-11.6	11.1	10.4
14.4	8	+	+14.4	14.1	
	4		+16.2	16.5	
18.3	4	+		19.4	
22.6	4	+		
25.0	2	-		24.3	24.3
29.0	1	+	+30.6	28.8	
.....				34.3, 37.5	
43.6	2	+		41.2	
46.5	4	+		48.	
.....				51.3	50
55.5	2	-		54.6	
63.8	3	-		62.	
.....				67.6	
70.4	3	-	-70.6	
.....				75.3, 82.7	80
85.1	1	+	85.1	87.1	
.....				91.2	
97.6	4	-		94.8	
.....				103.5, 112.2	
119.4	1	-		120
.....				125.7	
157.2	2	-		seventeen	160
175.6	2	-		potentials	171
193.3	(?)	-		omitted	200
227.3	(?)	-			
257	2	-			
290.	1	-	290	288.6	
.....				303.7, 331	
348	5	-	348	
390	1	-		
455	2	-		
.....				639	
720	1	-		704.3	
.....				818.5	
1040	?	+		
1370	?	+		

An indication of the agreement of the results for iron in the region 38 to 54 volts is given by Fig. 5. This region is more satisfactory than the average, however. In particular the region 100 to 400 volts is difficult to interpret; what appears to be gradual curvature in this region may be due to a number of small breaks. Above 500 volts in

iron changes of slope seem to occur at a few fairly definite points in good agreement on all curves; but corresponding points for nickel and molybdenum are hard to locate.

In Table I the first column gives the critical potential for secondary emission from iron determined in the present investigation. In accordance with the suggestions followed by Thomas,¹³ the value of the work function for iron, 5 volts, has been added to the observed values. The

TABLE II
Critical primary potentials for nickel

Critical potential	Weight factor	Sign	General breaks	x-rays levels (Thomas)
6.2	2	+	
9.3	3	-		8.6
9.9	3	-	-9.9
11.8	5	+		11.74
15.1	3	+	+15.1	14.6
.....				16.56, 18.0
22.6	4	+		22.2
.....			+23.5
24.4	2	+		
.....				27.25
31.4	5	+	31.4	30.97
35.0	2	+		34.6
.....				39.8, 44.65
48.2	3	+	+47.
.....				51.3, 54.8
58.5	1	+		57.4
.....				65.6
72.6	?	-	71.9	71.9
.....				79.8
84.5	1	+		87.2
.....				91.2, 94.9
.....			98.3
.....			106.5
115.3	?	-	-115.	116.6
172	?			(fourteen omitted)
262	2		262	265.9
.....				280, 286.5, 294.9
.....				311.5, 341.3
356	5	-	365
455	5	-	455
503	1	-		
.....				774, 833.4
.....				948, 1017.3

second column gives an estimate of the importance of the break based on intensity and on definiteness of location. All breaks except those of weight (1) were shown with fair agreement by all curves over the ranges concerned. The third column shows whether the break was due to an

¹³ C. H. Thomas, Phys. Rev. **25**, 322 (1925).

increase of slope (+) or a decrease (-). The fourth column gives breaks which appear when curves with much larger voltage intervals are plotted, so as to average out all breaks which do not result in a change of slope which persists over at least a considerable voltage interval. The fifth column gives results by Thomas for soft x-ray levels for iron. Breaks observed by Thomas since the paper to which reference is made was published are included. Seventeen breaks between 130 volts and 280 volts have been omitted in this column since comparison between the few values in the first column and the large number found here by Thomas would be without significance. The sixth column gives results for critical potentials in secondary emission from iron reported by Stuhlman.¹²

TABLE III
Critical primary potentials for molybdenum

Critical potential	Weight	Sign	General breaks
4.9	2	+	
7.3	1	-	
8.4	8	-	-8.5
12.7	5	+	+12.7
15.0	2	+	
16.5	1	+	
22.5	3	+	
30.5	4	+	
37.4	2	+	
41.9	3	-	-42
50.7	?	-	
53.9	1	-	
59.3	1	-	
65.8	0	+	
79.5	3	-	-79.
82.8	1	-	
101.9	?	-	
111.4	?	-	
131.3	0	-	
206.5	1	+	
298	2	-	-298
356	4	-	-356
473	1	-	

Table II similarly gives the results of the present investigation with nickel and the unpublished results obtained by Thomas for soft x-ray levels for nickel. Again 5 volts for the work function of nickel have been added to the results of both observers to give the data of columns 1 and 4. Table III shows the breaks observed in secondary emission from molybdenum; 4.3 volts have been added for the work function of molybdenum. No detailed data are available for comparison.

DISCUSSION OF RESULTS

Tables I and II show good agreement between columns 1 and 5 up to 40 volts. Above that voltage column 5 begins to have more values than column 1 and above 100 volts a comparison would be of no value. The curvature observed in this region in the secondary emission curves may be due to a large number of breaks, each too faint to be located separately. If several breaks of column 5 are interpreted as a single break in column 1 the agreement should disappear. However, no breaks are found by Thomas between 331 and 639 volts for iron and between 341 and 774 volts for nickel, while one of the more definite points in the secondary emission curves, the point at which the ratio reaches a maximum, comes in these regions, at 348 volts for iron and at 455 volts for nickel. Therefore it appears that, in the two investigations different effects have been studied at high voltages and that in the present work the effect of photo-electric emission due to x-radiation is not detectable because of larger effects which mask it.

It has been shown by Farnsworth¹¹ that a negative break may be accounted for by assuming that inelastic impacts begin to occur at critical voltages so that, after such a collision, neither the primary electron nor the electron with which the collision occurs has sufficient energy to escape from the metal. It may be noted that if the work function of nickel and iron is 5 volts, all electrons with a velocity less than 5 volts will fail to escape from the metal so that the curves might be expected to show negative breaks at the critical potentials for inelastic impact, followed by weaker positive breaks at an interval of 5 volts.

The meaning of the decreasing value for the ratio with increasing velocity of impact at high velocities is in doubt; there is no apparent reason why the probability of escape after a collision should decrease with increasing velocity unless a large part of the primary electrons penetrate to a comparatively great depth before making a collision, so that secondary electrons are less likely to escape.

In conclusion the writer wishes to thank Professor K. T. Compton, at whose suggestion this problem was taken up, for his constant interest and frequent assistance in the work.

PALMER PHYSICAL LABORATORY,
Princeton, New Jersey.
May 20, 1925.