

# Imaging with the gas electron multiplier

Fabio Sauli\*

*INFN Trieste and CERN, Geneva, Switzerland*

Available online 10 July 2007

## Abstract

The Gas Electron Multiplier (GEM), introduced several years ago, is finding numerous applications thanks to its excellent performances in detecting and localizing ionizing radiation. This note summarizes recent developments of the technology, and presents some examples of applications.

© 2007 Elsevier B.V. All rights reserved.

*PACS:* 29.40.Cs; 29.40.Gx

*Keywords:* Gas electron multiplier (GEM); Radiation imaging

The Gas Electron Multiplier (GEM) is a thin polymer foil, metal-coated on both sides, chemically etched with a high density of holes (typically, 50–100  $\mu\text{m}^2$ ). On application of a voltage between the two conducting sides, a high dipole field is created in the holes; each hole then acts as individual proportional counter. Electrons released by ionization on one side of the foil drift into the holes and multiply in avalanche before emerging on the other side [1]. The amplified charge can be detected on a patterned electrode, or drifted into a second GEM foil for further amplification. Cascading several multipliers allow to obtain higher gains, or given the gain a safer operation; this is particularly important in presence of heavily ionizing background [2]. Fig. 1 shows schematically a Triple-GEM detector. Typical distances between the electrodes are of 1 or 2 mm; the sensitive (or drift) volume can vary from a few millimeters, in fast tracking applications, to several meters in Time Projection Chambers. Although each electrode can be powered individually, a single resistor chain can be used for simplicity of operation. With the structure shown, proportional gains around  $10^4$  can be reliably achieved even in harsh radiation environment, a solution adopted for example for the GEM detectors of COMPASS [3] and LHCb [4].

The main performances of a GEM-based detector can be summarized as follows: two-dimensional position accuracy of 50  $\mu\text{m}$  or better; rate capability exceeding  $1 \text{ MHz mm}^{-2}$ ; proportional gains above  $10^5$ , allowing detection of single electrons; efficiency for minimum ionizing particles close to 100%. To this one should add convenience of assembly, in a variety of shapes and readout electrode pattern. A set of 20 medium-size GEM detectors, each with two-dimensional projective readout, built at CERN for the COMPASS spectrometer has operated flawlessly for several years in a high-intensity beam [5]. Fig. 2 shows a GEM detector with semi-circular shape, designed for installation over the beam tubes of CERN's LHC accelerator; 40 identical modules are in construction for the TOTEM experiment. The detector has radial strips for accurate angle measurements, and pad rows providing fast signals for fast triggering [6]. Thanks to the flexibility of the GEM foils, non-planar detectors are possible; Fig. 3 shows as an example a semi-cylindrical prototype built at CERN and under development for an experiment upgrade [7]; a similar device with pad readout is operational at Jefferson Lab [8].

A GEM-based readout for Time Projection Chambers has many advantages compared to a conventional MWPC: narrower pad response function (millimeters instead of centimeters); signals induced only by fast electrons (no “ion tail”), with a correspondingly improved two-track resolution; absence of distortions due to regions of non-parallel electric and magnetic field due to wires (the ExB effect);

\*Tel.: +41 22 7673670.

E-mail address: [Fabio.sauli@cern.ch](mailto:Fabio.sauli@cern.ch)

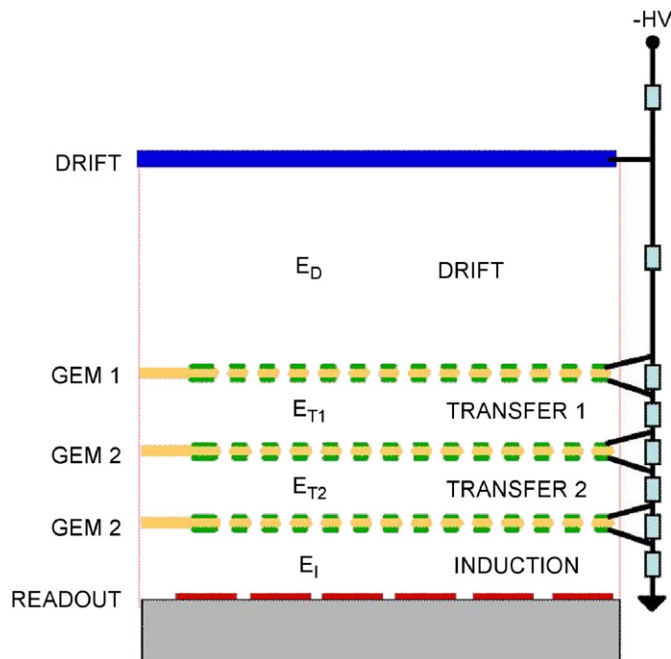

Fig. 1. Schematics of a Triple-GEM detector.

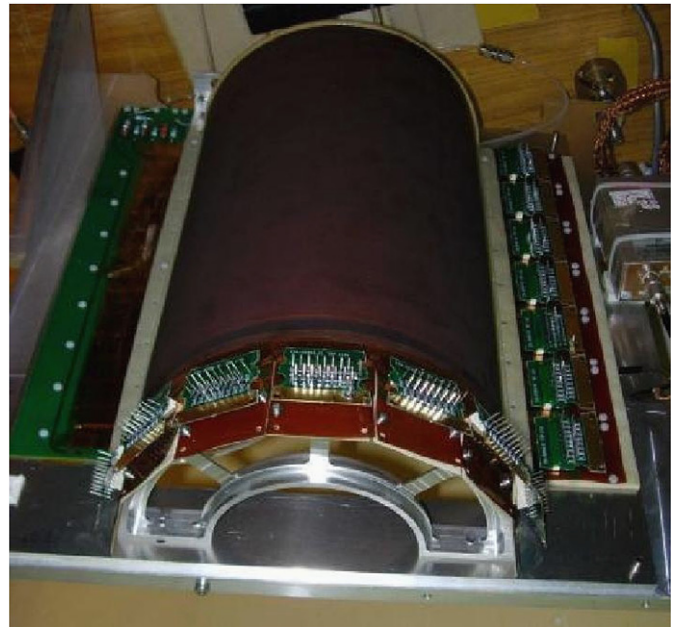

Fig. 3. A semi-cylindrical GEM detector under development at CERN.

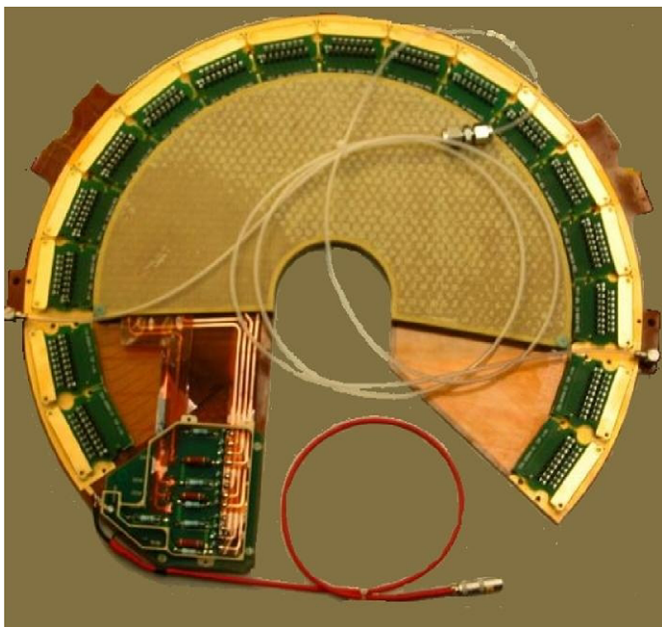

Fig. 2. Half-moon GEM detector module for TOTEM at CERN.

substantial reduction of the positive ion feedback (a percent or less, as compared to 20–30%). For these reasons, many groups have built and tested GEM-TPC prototypes, particularly in view of their use for the International Linear Collider; in presence of a strong magnetic field (4 T), the reduction of transverse electron diffusion has permitted to achieve localization accuracies in the drift time direction of around 100  $\mu\text{m}$ , for up to a meter drift length [9]. Use of a low diffusion gas, such as carbon tetrafluoride ( $\text{CF}_4$ ) allows to obtain similar

accuracies even in absence of magnetic field [10]. Despite the practical difficulties connected to the use of  $\text{CF}_4$ , in particular the required purity, the low diffusion and low neutron cross-section are great advantages.

Efficient in detection of charged particles and soft X-rays, GEM devices, as all gaseous detector, are unsuitable for imaging of energetic X- or gamma-rays. A way to increase efficiency is to interleave conversion foils or grids with GEM foils, or replace the thin metal GEM electrodes with thicker foils, an approach pursued by the Stockholm group [11]. Fig. 4 shows a few frames of a time-resolved hard X-ray radiography, recorded with a GEM-converter prototype, at 70 frames  $\text{s}^{-1}$ . This direction of research is very promising in medical diagnostics, including on-line portal imaging during the therapeutic irradiations [12].

All applications discussed so far use a classic readout scheme, strips or pads read out by external amplifiers and recorders. Recently, a novel approach has been developed, with the use of solid-state sensors directly collecting the charge. A work in this direction is the GEM polarimeter, a high-resolution detector capable of sub-millimeter imaging of ionization trails of photoelectrons produced in the gas by soft X-rays (5–10 keV). Recording and reconstruction of the trail allows to deduce the initial direction of the photoelectron, and therefore the polarization of the incident X-ray [13]. Fig. 5 gives an example of an event, recorded with an ASIC readout chip with 50  $\mu\text{m}$  pixel size [14]; the area of the blobs represents the pixel charge, and one can clearly recognize the emission point and the final Bragg peak: the whole track is contained within about 1  $\text{mm}^2$ .

In conclusion, GEM-based detectors appear to be a powerful addition to the inventory of fast,

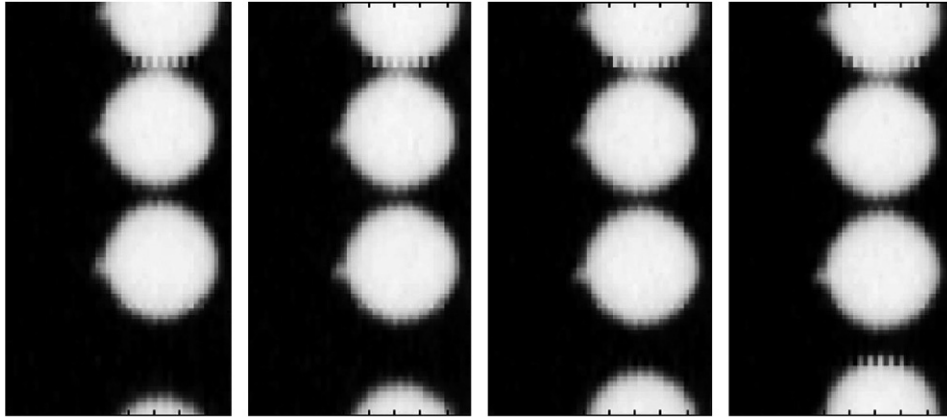

Fig. 4. Time-resolved X-ray absorption images of a pendulum.

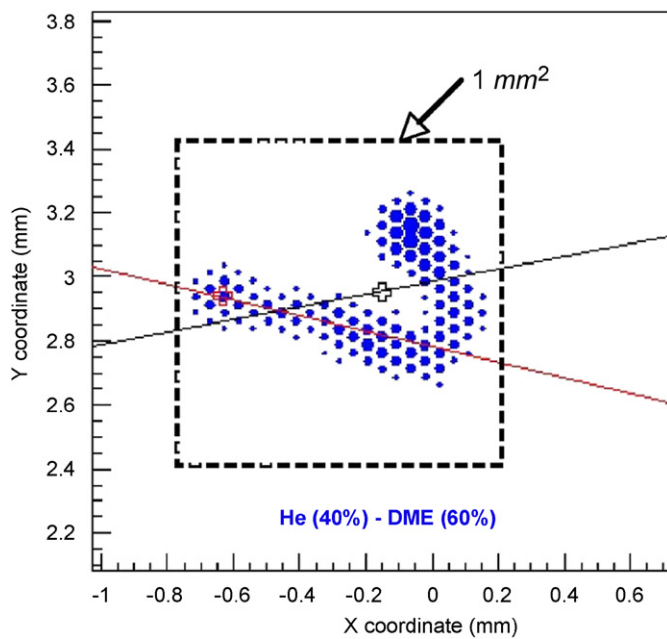

Fig. 5. 6 keV photoelectron track recorded with the X-ray polarimeter.

position-sensitive radiation detectors; many applications have been found in particle physics and other fields, and many others are under development.

## References

- [1] F. Sauli, Nucl. Instr. and Meth. A 386 (1997) 531.
- [2] S. Bachmann, et al., Nucl. Instr. and Meth. A 470 (2001) 548.
- [3] C. Altunbas, et al., Nucl. Instr. and Meth. A 490 (2002) 177.
- [4] G. Bencivenni, et al., Nucl. Instr. and Meth. A 478 (2002) 245.
- [5] B. Ketzer, et al., Nucl. Instr. and Meth. A 535 (2004) 314.
- [6] E. Noschis, et al., Nucl. Instr. and Meth. A 572 (2006) 378.
- [7] L. Ropelewski, Private communication at CERN.
- [8] H. Fenker, The BoNuS Detector: A Radial Time Projection Chamber for tracking Spectator Protons, JLAB-PHY-04-1, 2004.
- [9] M. Killenberg, et al., Nucl. Instr. and Meth. A 530 (2004) 251.
- [10] S.X. Oda, et al., Nucl. Instr. and Meth. A 566 (2006) 312.
- [11] J. Ostling, et al., IEEE Trans. Nucl. Sci. NS-50 (2003) 809.
- [12] J. Östling, New efficient detector for radiation therapy imaging using gas electron multipliers, Thesis at Stockholm University, 2006.
- [13] E. Costa, et al., Nature 411 (2001) 662.
- [14] R. Bellazzini, et al., Nucl. Instr. and Meth. A 576 (2007) 183.